

ADEMCO 5890 PASSIVE INFRARED MOTION DETECTOR/TRANSMITTER

INSTALLATION AND SETUP GUIDE

GENERAL INFORMATION

The 5890 Passive Infrared Motion Detector/Transmitter is a battery-operated wireless device intended for use as part of a 5800 Series wireless alarm system.

Designed for use in commercial and residential installations, the 5890 is a wall-mounted unit with a standard lens that provides wide-angle protection up to a range of 40 feet (12m). For best coverage, mount the detector so that the likely direction of intruder motion is across the pattern.

Two optional interchangeable lenses are available for this detector – the 199PA Pet Alley lens, and the 199LR Long Range lens (see *PROTECTION PATTERNS FOR OPTIONAL LENSES* on last page).

This document provides installation instructions for the 5890, but the installer must be familiar with the Installation Instructions for the 5800 Wireless Alarm System with which the 5890 is intended to be used.

FEATURES

- Wireless operation for fast installation.
- Dual-element pyro-electric sensor provides positive protection while minimizing false alarms.
- Alternate-polarity pulse count option offers greater stability in adverse environments.
- Provision to turn LED on while Walk Testing (LED is turned off after testing).
- Tampered cover – unit transmits message if cover is removed.
- Wall or corner mounting options.
- Optional Pet Alley and Long Range lenses available.

SYSTEM DESCRIPTION

Optical System: Uses efficiently designed Fresnel lenses.

Radio Transmitter: The built-in transmitter serves only as the communication link to the alarm system's Receiver/Control, and can send alarm, tamper, supervisory, and battery status messages to the system's receiver/control. The transmitter is not used for detection purposes. Each detector has a unique ID code permanently assigned at the factory. This ID needs to be "enrolled" by the control system at the time of installation. This allows each detector used in the system to be uniquely identified. The control must be programmed to "enroll" the 5890 as an "RF" type unit (i.e., supervised RF).

To conserve battery life during normal operation, no more than one transmission sequence will occur within a 3-minute period. There is no such time restriction in "test" mode.

Alternate Polarity Pulse Count: Two jumper-selectable detection response modes are provided: *Instant response* (Pulse Count OFF) and *Alternate Polarity Pulse Count* (Pulse Count ON). With Pulse Count OFF, any detected change in infrared energy will trigger an immediate alarm signal. This mode is recommended when the detector is used to monitor a narrow hallway where coverage is provided by only a single zone.

Use the Pulse Count ON mode when the detector is installed in areas where periodic changes in infrared energy levels are normal (for example, where forced air heating ducts are present).

In this mode, it requires at least two detected changes in infrared energy within a short period before an alarm will be triggered.

Important Note: If the detector is to be used in the Pulse Count mode, be sure to Walk Test the unit in this mode.

SPECIFICATIONS

Coverage:

Standard Lens: 40 ft x 56 ft (12m x 17m).
18 zones (9 long, 5 intermediate, 4 short range).

199LR Lens: 60 ft x 6 ft (18m x 1.8m).
5 zones (1 long, 2 intermediate, 2 short range).

199PA Lens: 40 ft x 60 ft (12m x 18m).
12 zones.

Pulse Count: Installer-selectable On/Off link.

Detectable

Walk Rate: 0.5 – 5ft/Sec (0.15 – 1.5m/Sec).

Mtg. Height: 7 ft nominal (2.1m) but may be mounted at other heights (see Table 1).

Walk Test

Indicator: Red LED with Test/Normal (disable) link.

Batteries:

Two 3-volt Lithium batteries. Use only ADEMCO No. 466, Duracell DL123A, Panasonic CR123A, Sanyo CR123A, or Varta CR123A.

Operating

Temperature: 32°F – 122°F (0°C – 50°C).

Operating

Humidity: Up to 95% RH (max.), non-condensing.

Dimensions:

2-11/16"W x 5"H x 1-7/8"D

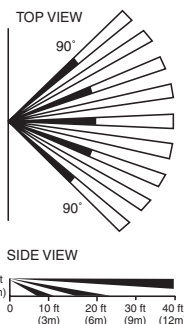

Figure 1.
Standard Wide-Angle Protection Pattern

BATTERY INSTALLATION

1. Remove front cover by inserting a large screwdriver blade (or small coin) in groove between cover and base at the location shown in Figure 2; rotate blade to override snap fit, then lift cover off.
2. **Observing correct polarity**, install the two Lithium batteries (supplied) into the battery holders, as shown in Figure. 5. Make sure the batteries are firmly seated.
3. Replace the cover (snap fit).

Battery Caution:

Risk of fire, explosion, and burns. Do not recharge, disassemble, heat above 100°C, or incinerate. Dispose of used batteries promptly. Keep away from children.

Programming Note: If the detector's ID has not been programmed into the system (i.e., this is an initial detector installation), refer to the *PROGRAMMING* section below and perform the ID "enrolling" procedure before mounting or testing the detector.

PROGRAMMING

You must "enroll" the detector's ID during installation of the system. **Program the 5890 as an "RF" type unit (i.e., supervised RF).**

To program the detector, place the LED jumper in the TEST position (see Figure 5), the Pulse Count jumper in the OFF position, batteries installed, and cover on. Temporarily cover the lens (a cloth will do) to prevent any activation by the detector.

When prompted for the device's serial number, you may either manually enter it or transmit from the unit (remove the cloth cover and motion your hand over the lens to activate the detector, press the tamper switch, etc.). Refer to the control panel installation instructions for programming details.

Return LED jumper to the NORMAL position after it is enrolled in the control.

INSTALLATION

Installation Hints

- Do not install where the detector is exposed to direct sunlight or directly above strong sources of heat.
- Make sure the detection area does not have obstructions (curtains, screens, large pieces of furniture, plants, etc.) that may block the pattern of coverage.
- Avoid locating a unit in areas that contain objects likely to produce a rapid change in temperature, such as central heating, radiators, or ducts (or heaters of any kind), air conditioners, open flame, etc.
- Do not mount on an unstable surface.

Radio Transmission Path Check

Verify that a strong transmission path between the 5890 and the system's Receiver/Control exists **before permanently mounting the detector**. Do this by performing the *Walk Test* (described later) with the detector temporarily mounted in its proposed location. The 5890 will transmit when sensing motion (when you wave an arm or walk into area). Sometimes, moving the detector only a few inches means the difference between a strong and weak transmission path. Experiment until you are satisfied that the location provides the strongest transmission path, while still being practical for the protection pattern desired.

This test also verifies that the detector has been correctly programmed into the system.

Normal Mounting

Mount the unit to a firm vertical surface (flat on wall or in corner).

1. Remove front cover.
2. Temporarily loosen (do not remove) the screw holding the PC board in the detector base (see Figure 5 for location of this screw).

The board can then be moved up or down for access to the knockout mounting holes in the base.

3. Refer to Figure 3 for location of knockout holes in the base. Break out only those holes required.
4. Mount the detector with screws, using the selected mounting holes.
5. Before fully tightening the PC board-holding screw, make sure the board is positioned so that the arrow is in line with the appropriate setting on the graduated scale on the right-hand side of the PC board (see Table 1 and Figure 5).

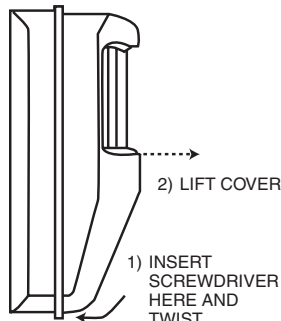

Figure 2. Cover Removal

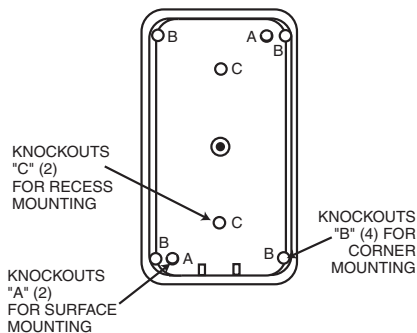

Figure 3. Mounting Holes in Base

CHANGING LENSES (if required)

1. Remove front cover.
2. Squeeze upper lens lock located in front cover to release upper Fresnel lens support. Squeeze lower lens lock to release lower Fresnel lens support (see Figure 4).
3. Note how the lens supports are positioned, then remove the supports.

4. Carefully remove the existing lens and replace with an optional coverage replacement lens. *The lens must be installed with the smooth side facing outward. Also, the lens should be oriented with its part number on the upper right-hand side (see Figure 4).* Be sure to center the lens.

Note: Lens surface should be free of dirt, foreign matter, and fingerprints. Use a clean, dry soft cloth to wipe lens surfaces, if required.

5. Replace top and bottom lens supports and then press downward so that the lens locks snap into position, thus securing the lens in place.
6. Refer to Table 1 for recommended PIR mounting height, pulse count setting, and pattern setting for the lens in use.
7. Replace the front cover (make sure the cover snaps tightly).

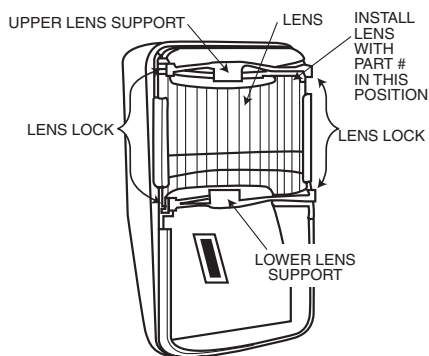

Figure 4. Changing Lenses

VERTICAL PATTERN ADJUSTMENT

The protection pattern provided by the lens in use can be raised or lowered by re-positioning the PC board in the detector. A graduated scale to the right of the board (see Figure 5) indicates the approximate number of degrees by which the pattern can be raised (max. +5°) or lowered (max. -15°). The detector is normally shipped with the board set to the 0° position. To make this adjustment, remove the cover on the detector and loosen the screw holding the PC board (the screw is located at the approximate center of the board). Slide the board upward or downward by the number of degrees required, then tighten the holding screw again. After any adjustment, you must conduct a Walk Test to ensure proper coverage of the area to be protected, as indicated under *TEST PROCEDURES*.

LENS MASKING

The masking strips that have been supplied are designed for application to one or more lens segments to produce a protection pattern that suits the particular requirements of the protected area. Individual masking strips have been provided for each of the lens segments on the standard lens supplied with the PIR. Simply peel off the appropriate pressure-sensitive adhesive strip(s) and apply over the desired lens segment(s). Be sure to affix the masking strips to the *inside* of the lens (not the outer, smooth side). Each lens segment that is masked results in the elimination of one zone of protection from the coverage pattern. By masking segments of the lens, you can adjust the coverage to suit the area to be protected, or eliminate coverage from areas where you anticipate environmental disturbances that might reduce the PIR's stability (a heater or other heat-producing object, for example).

Important: When hallway pattern masking is used, be sure the PIR is set for instant response.

HORIZONTAL ADJUSTMENT OF LENS

The protection pattern provided by the lens can be moved to the left or right by horizontal adjustment of the lens, as follows:

1. Remove front cover.
2. Press inward on the upper and lower lens locks at the left or right side only to release the lens supports on one side. Now slide the lens to the left or right, as needed. The lens may be moved as much as 8° (from center) in either direction.
3. When the lens is in the desired position, press the lens locks downward (on the released side) to lock the supports in place.
4. Replace the front cover (make sure the cover snaps tightly).

After any adjustment, you must conduct a Walk Test to ensure proper coverage of the area to be protected, as indicated under *TEST PROCEDURES*.

PULSE COUNT OPTION

Each detector includes pulse count circuitry that is designed to provide stability in adverse environments to minimize false alarms. Pulse count is selected by positioning a jumper across the ON pulse count terminals (shown in Figure 5). When set for pulse count, the detector will signal an alarm within 2 or 3 steps, since the processing logic requires more complex motion than just a momentary event. When the detector verifies an intrusion, the built-in transmitter sends an alarm message to the control/receiver.

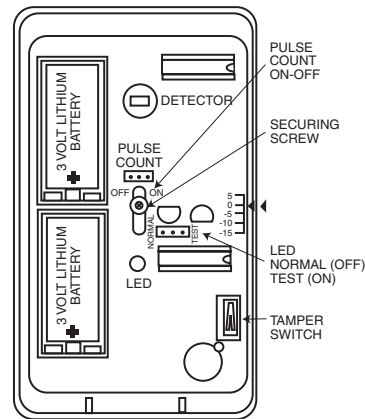

Figure 5. PC Board

OPTIONAL LENSES

Two optional lenses are available for use with the PIR. Information about these lenses is provided in Table 1. Refer to *CHANGING LENSES* in this document if one of the optional lenses is being installed in place of the standard lens.

TEST PROCEDURES

Important: Testing should be conducted with the protected area cleared of all people. Place the protective system's control in the Test mode for the Walk Test procedure. When the PIR senses movement, a "beep" will be heard from the system's console to verify that the PIR's transmitter signal has reached the control's wireless receiver.

The absolute range of all PIR units is subject to variation because of different types of clothing, backgrounds, and ambient temperature. For this reason, ensure that the most likely intruder routes are well within the PIR's protective zones and that Walk Testing is carried out along these routes.

WALK TEST

1. Remove front cover and set the pulse count jumper in the detector in the OFF position initially. The LED must be enabled at this time (jumper in the TEST position).

LED DISABLE

The detector is shipped with the LED disabled (LED jumper in the "NORMAL" position). The LED may be enabled (for the Walk-Test) by positioning the LED jumper in the "TEST" position (see Figure 5).

Note: When the jumper is in the "NORMAL" position, the LED will not light, but the built-in transmitter will transmit alarms when the PIR senses motion.

2. Replace front cover and walk through protective zones, observing that the detector's LED lights whenever motion is detected (the LED serves as a Walk Test indicator during this procedure).

3. If pulse count is going to be used in this installation, set the pulse count jumper to the ON setting and repeat the Walk Test procedure.

Note: If pulse count mode is used during the Walk Test, the LED will stay lit for approximately 1 to 3 seconds after detecting motion.

4. **After the Walk Test is completed, the LED jumper should be placed in the NORMAL position (LED disabled). Failing to do so will reduce the battery life.**

MAINTAINING PROPER OPERATION

In order to maintain the detector in proper working condition, it is important that the user observes the following:

1. Replace **both** batteries within 7 days after a "low battery" message has appeared in the system's display.
2. Detectors should never be reamed or relocated without the advice or assistance of the alarm service company.

3. The physical surroundings of the protected area should not be changed. If furniture or stock is moved, or air conditioning or additional heating is installed, the PIR may have to be readjusted.
4. Walk Tests should be conducted frequently (at least weekly) to confirm continued proper coverage.

TABLE 1. INSTALLATION GUIDE FOR FRESNEL LENSES

Lens Part No.	Description/Coverage	Pulse Count	PIR Mounting Height	Range to Be Covered	Pattern Setting (Deg) †
5890 Standard (No. 1000)	WIDE ANGLE LENS 40 ft x 56 Ft (12m x 17m)	Optional	6 ft (1.8m)	40 ft (12m)	-1°
				30 ft (9m)	-3°
				15 ft (4.6m)	-11°
			7 ft (2.1m)	40 ft (12m)	-2.5°
				30 ft (9m)	-5°
				15 ft (4.6m)	-15°
			8 ft (2.4m)	40 ft (12m)	-4°
				30 ft (9m)	-7°
				15 ft (4.6m)	**
OPTIONAL FRESNEL LENSES					
199PA	PET ALLEY LENS 40 ft x 60 Ft (12m x 18m)	Optional	3-4.5 ft (0.9m-1.4m)		+7°
199LR	LONG RANGE LENS 60 ft x 6 ft (18m x 1.8m)	OFF*	6 ft (1.8m)	60 ft (18m)	+1°
				40 ft (12m)	-1°
				20 ft (6m)	-6°
			7 ft (2.1m)	60 ft (18m)	0°
				40 ft (12m)	-2.5°
				20 ft (6m)	-9°
			8 ft (2.4m)	60 ft (18m)	-1°
				40 ft (12m)	-4°
				20 ft (6m)	-12°

† See Figure 5 for location of adjustment scale on PC board (refer also to VERTICAL PATTERN ADJUSTMENT).

* Always set pulse count OFF with the Long Range lens.

** For distances of 20 ft (6m) and less, adjust to maximum negative (board at highest position).

TROUBLESHOOTING

Trouble 1: INTERMITTENT ALARM

Probable Causes:

- A. Rapid temperature change. Check for electric or gas heaters, open flames, electric arcs, etc.

Remedy: Locate source and reposition detector.

- B. Drafts causing drapes, light fixtures, display material to move.

Remedy: Eliminate source of motion.

Trouble 2: LED INOPERATIVE DURING WALK TEST

Probable Causes:

- A. LED control jumper set to NORMAL.

Remedy: Re-position jumper to TEST position.

- B. LED malfunction. Check for broken/shorted leads.

Remedy: Return unit for service.

Trouble 3: DETECTION AREA CHANGES

Probable Causes:

- A. Re-positioned furniture or equipment in the protected area.

Remedy: Caution customer about layout changes. Reposition detector.

- B. Mounting surface is unstable. A few degrees of vertical shift can change range substantially.

Remedy: Mount on secure surface.

Trouble 4: UNIT DOES NOT APPEAR TO BE OPERATING

Probable Cause:

- A. Unit is not receiving power.

Remedy: Check for appropriate battery voltage. Install new batteries if necessary. Be sure to change both batteries.

PROTECTION PATTERNS FOR OPTIONAL LENSES

No. 199PA, Pet Alley Lens

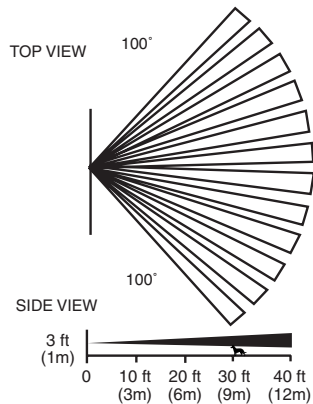

No. 199LR, Long Range Lens

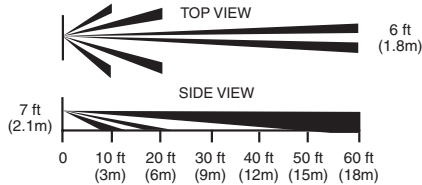

LIMITATIONS OF THE PIR MOTION DETECTOR

While the Intrusion Detector is a highly reliable intrusion detection device, it does not offer guaranteed protection against burglary. Any Intrusion Detection device is subject to compromise or failure to warn for a variety of reasons:

- Passive Infrared Motion Detectors can only detect intrusion within the designed ranges as diagrammed in this installation manual.
- Passive Infrared Motion Detectors do not provide volumetric area protection. They do create multiple beams of protection, and intrusion can only be detected in unobstructed areas covered by those beams.
- Passive Infrared Detectors cannot detect motion or intrusion that takes place behind walls, ceilings, floors, closed doors, glass partitions, glass doors, or windows.
- Mechanical tampering, masking, painting, or spraying of any material on the lenses, windows, or any part of the optical system can reduce the detection ability of the Passive Infrared Motion Detector.
- Passive Infrared Detectors sense changes in temperature; however, as the ambient temperature of the protected area approaches the temperature range of 90° to 105°F (32° to 40°C), the detection performance can decrease.
- This Passive Infrared Detector will not operate without the appropriate battery installed, or if the battery is weak or improperly connected (i.e., reversed polarity).
- Passive Infrared Detectors, like other electrical devices, are subject to component failure. Even though this equipment is designed to last as long as 10 years, the electronic components in it could fail at any time.

We have cited some of the most common reasons that a Passive Infrared Motion Detector can fail to catch intrusion. However, this does not imply that these are the only reasons, and therefore it is recommended that weekly testing of this type of unit, in conjunction with weekly testing of the entire alarm system, be performed to ensure that the detectors are working properly.

Installing an alarm system may make the owner eligible for a lower insurance rate, but an alarm system is not a substitute for insurance. Homeowners, property owners, and renters should continue to act prudently in protecting themselves and continue to insure their lives and property.

We continue to develop new and improved protection devices. Users of alarm systems owe it to themselves and their loved ones to learn about these developments.

LIMITED WARRANTY

Honeywell International Inc., acting through its Security & Custom Electronics business ("Seller") 165 Eileen Way, Syosset, New York 11791, warrants its product(s) to be in conformance with its own plans and specifications and to be free from defects in materials and workmanship under normal use and service for 24 months from the date stamp control on the product(s) or, for product(s) not having a manufacturer's date stamp, for 12 months from date of original purchase unless the installation instructions or catalog sets forth a shorter period, in which case the shorter period shall apply. Seller's obligation shall be limited to repairing or replacing, at its option, free of charge for materials or labor, any product(s) which is proved not in compliance with Seller's specifications or proves defective in materials or workmanship under normal use and service. Seller shall have no obligation under this Limited Warranty or otherwise if the product(s) is altered or improperly repaired or serviced by anyone other than Honeywell factory service. For warranty service, return product(s) transportation prepaid, to Honeywell Factory Service, 165 Eileen Way, Syosset, New York 11791.

THERE ARE NO WARRANTIES, EXPRESS OR IMPLIED, OF MERCHANTABILITY, OR FITNESS FOR A PARTICULAR PURPOSE OR OTHERWISE, WHICH EXTEND BEYOND THE DESCRIPTION ON THE FACE HEREOF. IN NO CASE SHALL SELLER BE LIABLE TO ANYONE FOR ANY CONSEQUENTIAL OR INCIDENTAL DAMAGES FOR BREACH OF THIS OR ANY OTHER WARRANTY, EXPRESS OR IMPLIED, OR UPON ANY OTHER BASIS OF LIABILITY WHATSOEVER, EVEN IF THE LOSS OR DAMAGE IS CAUSED BY THE SELLER'S OWN NEGLIGENCE OR FAULT.

Seller does not represent that the product(s) it sells may not be compromised or circumvented; that the product(s) will prevent any personal injury or property loss by burglary, robbery, fire or otherwise; or that the product(s) will in all cases provide adequate warning or protection. Customer understands that a properly installed and maintained alarm system may only reduce the risk of a burglary, robbery, fire, or other events occurring without providing an alarm, but it is not insurance or a guarantee that such will not occur or that there will be no personal injury or property loss as a result. CONSEQUENTLY, SELLER SHALL HAVE NO LIABILITY FOR ANY PERSONAL INJURY, PROPERTY DAMAGE OR OTHER LOSS BASED ON A CLAIM THAT THE PRODUCT(S) FAILED TO GIVE WARNING. HOWEVER, IF SELLER IS HELD LIABLE, WHETHER DIRECTLY OR INDIRECTLY, FOR ANY LOSS OR DAMAGE ARISING UNDER THIS LIMITED WARRANTY OR OTHERWISE, REGARDLESS OF CAUSE OR ORIGIN, SELLER'S MAXIMUM LIABILITY SHALL NOT IN ANY CASE EXCEED THE PURCHASE PRICE OF THE PRODUCT(S), WHICH SHALL BE THE COMPLETE AND EXCLUSIVE REMEDY AGAINST SELLER.

This warranty replaces any previous warranties and is the only warranty made by Seller on this product(s). No increase or alteration, written or verbal, of the obligations of this Limited Warranty is authorized.

FCC STATEMENT

FCC ID: CFS8DL5890 CANADA: 1748K1405 5 3

This device complies with Part 15 of the FCC Rules. Operation is subject to the following two conditions:

- (1) This device may not cause harmful interference.
- (2) This device must accept any interference received, including interference that may cause undesired operation.

Honeywell

165 Eileen Way, Syosset, New York 11791

Copyright © 2004 Honeywell International Inc.

www.honeywell.com/security



N5987V3 5/04 Rev. A