

FlexGuard® FG1625SN V-Plex Glassbreak Detector Installation Instructions

Refer to Supplemental Information (next page) for complete descriptions of these installation steps

FG1625SN V-Plex Glassbreak Detector

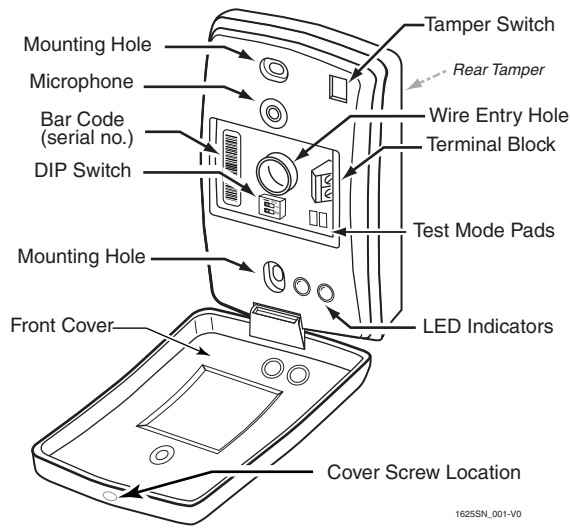

Select Mounting Location

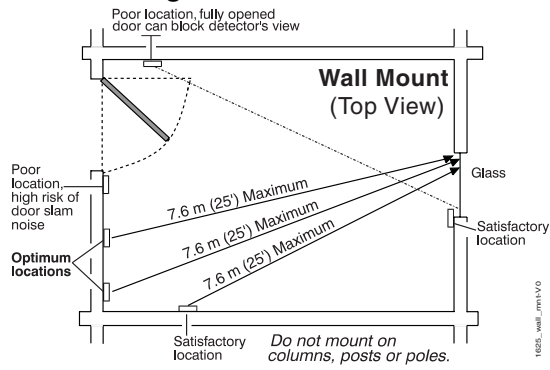

Test Location w/ 9V Battery

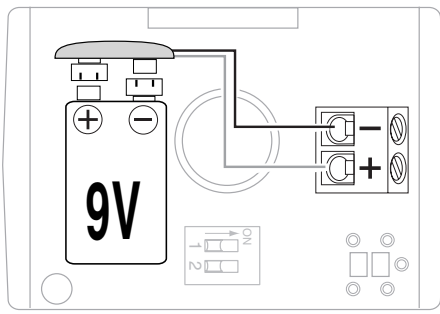

Set Sensitivity Configuration

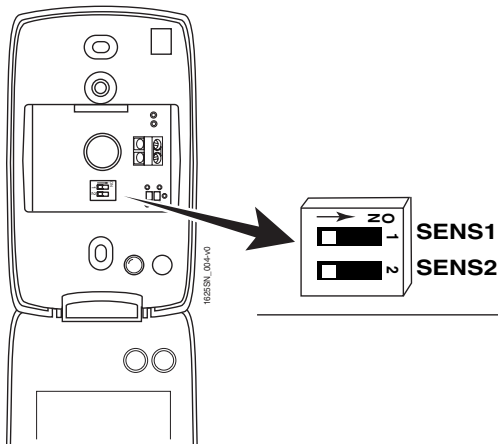

SENS1 & SENS2 configure sensitivity

SENSITIVITY	APPROXIMATE RANGE	SENS1	SENS2
MAX	25 ft (7.6m)	OFF	OFF
MEDIUM	15 ft (4.6m)	ON	OFF
LOW	10 ft (3m)	OFF	ON
LOWEST	5 ft (1.5m)	ON	ON

Note: Ranges are approximate and vary with each room's acoustic properties. Always verify range with a FG-701 Glassbreak Simulator.

Enable Wall Tamper

- Remove plastic tab from rear of detector.
- Install wall tamper screw as shown.
- Set screw depth to make contact w/ bottom of tamper cavity when device is installed

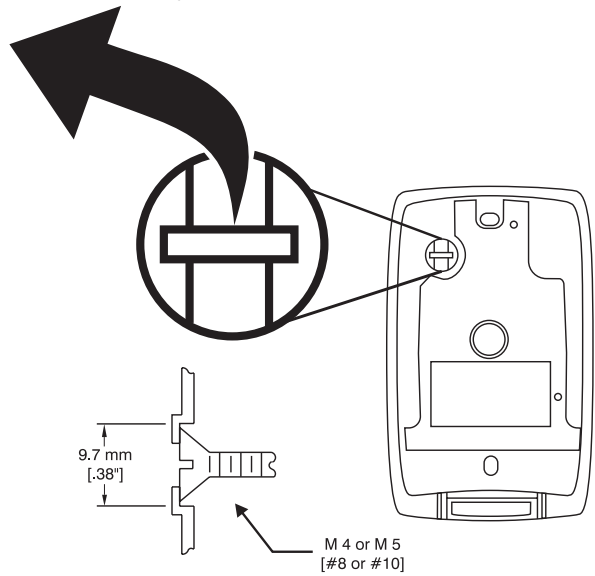

Connect Detector

Connect detector to the polling loop using 18 to 22 AWG wire, with ends stripped approximately 6mm (1/4 inch). Be sure to observe proper polarity!

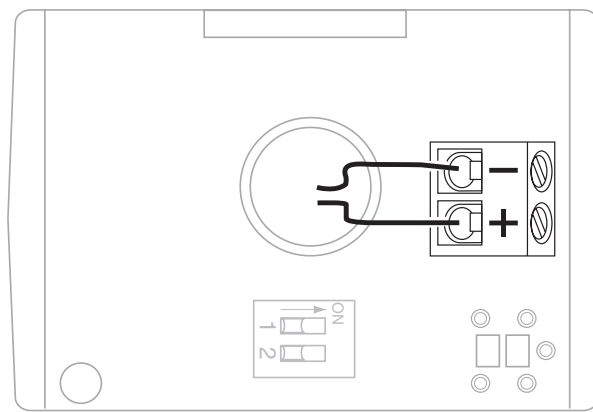

FG1625SN V-Plex (Polling Loop) Wiring

Prepare Housing for Surface Wiring (Optional)

The back of the housing has four wire channels to accommodate surface wiring. If surface wiring is to be used, select the appropriate wire channel and remove the breakout tab by inserting a flathead screwdriver under the tab and prying upward.

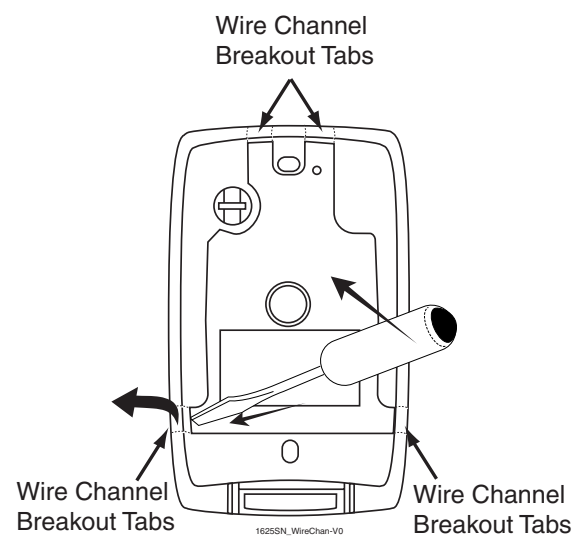

Mount Detector

- Place unit over wall tamper screw, if used.
- Use mounting holes as template to mark ceiling or wall.
- Mount detector using appropriate hardware.

NOTE: A screw capture feature designed to make ceiling mounting easier will cause some resistance when inserting the screw into the plastic.

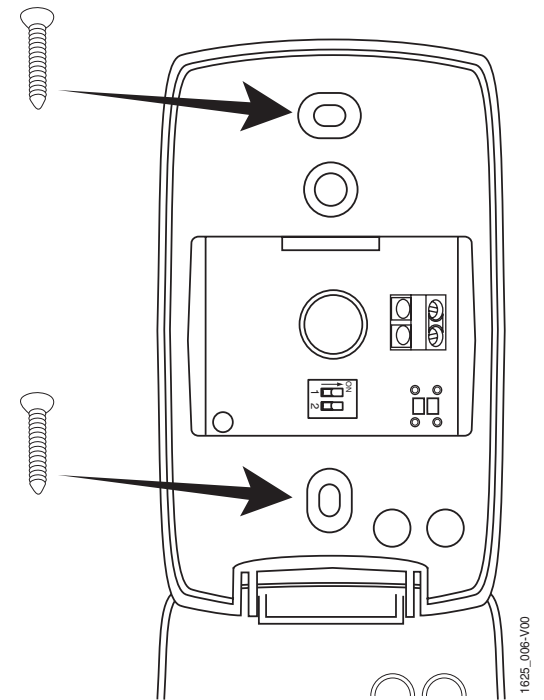

Test Detector Installation

Enter Test Mode using FG-701 (see Testing the Detector on the next page) or manually by shorting Test Mode pads (as below). Test Mode will automatically time out after five minutes.

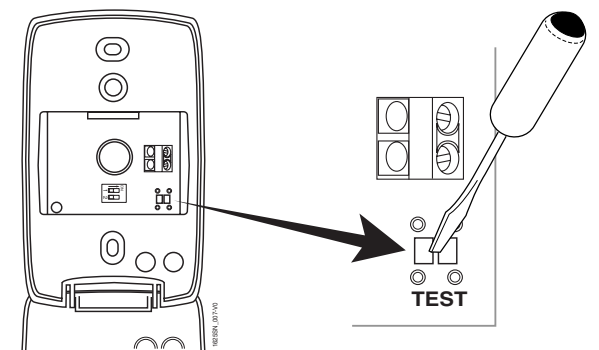

IMPORTANT NOTE: Close Cover while testing.

Install Cover Screw (optional)

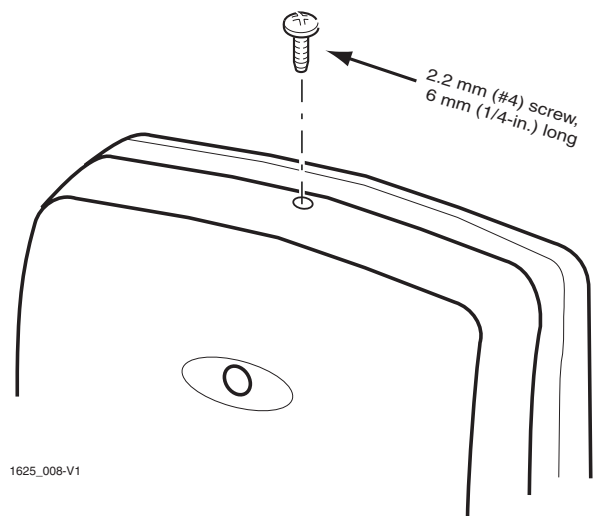

FlexGuard® FG1625SN V-Plex Glassbreak Detector Supplemental Information

Refer to Installation Instructions and diagrams (next page) when installing this product

1. General Information

The FG1625SN glassbreak detector senses the sound of breaking plate, tempered, laminated, wired, coated, and sealed insulating glass. This device is designed for use only with controls supporting V-Plex (polling loop) technology.

Control units for use in Canada utilizing polling loops require compatibility analysis by Underwriters' Laboratories of Canada for glass break detectors that are intended to be connected to these control units. Refer to the Installation Instructions for the control unit before installing burglar alarm equipment.

NOTE: The FG1625SN does NOT illuminate its LEDs on power-up. LEDs operate only in Test Mode.

2. Choosing Mounting Location

The preferred mounting location for the device is on a wall or ceiling, opposite the protected glass.

For the best detector performance, select a mounting location that is:

- within 7.6 m (25 feet) of the protected glass;
- within clear view of the protected glass;
- at least 2 m (6.5 feet) from the floor;
- at least 1 m (3.3 feet) from forced air ducts;
- at least 1 m (3.3 feet) from sirens or bells greater than 5 cm (2 inches) in diameter.
- between the protected glass and any heavy window coverings that may be present. Alternatively, when heavy window coverings are present, the detector can be mounted on the frame of the window.

Avoid mounting the detector on the same wall as the protected glass, on free-standing posts or pillars, or in rooms with noisy equipment (air compressors, bells, power tools, etc.), if this equipment is operated when the detector is armed.

3. Testing Mounting Location

You can test the detector in the desired mounting location before drilling/wiring by connecting a 9V battery to the polling loop terminal block. Observe the polarity marked on the PC board. After applying power, allow ten seconds for the unit to stabilize before testing. Follow the procedure described in "Testing the Detector" (next column) to confirm proper operation.

4. Configuring Sensitivity (Range)

DIP switches SENS1 and SENS2 set detector sensitivity (range), as shown:

SENSITIVITY	RANGE *	SENS1	SENS2
MAX	25 ft (7.6m)	OFF	OFF
MEDIUM	15 ft (4.6m)	ON	OFF
LOW	10 ft (3m)	OFF	ON
LOWEST	5 ft (1.5M)	ON	ON

*In order to maximize false alarm immunity, Sensitivity must be set to match the distance between the detector and the protected glass, as verified using the FG-701 (or GBS-7) Glassbreak Simulator (see next page).

5. Enabling Rear Tamper

The FG1625SN is equipped with normally-closed (NC) cover and wall tamper switches. Each unit is shipped with the cover tamper operational, and the wall tamper disabled.

To enable the rear tamper, remove the plastic tab on the back of the detector, using needle-nose pliers. The wall tamper arm will extend through the hole. *Proceed with the mounting instructions to install the wall tamper screw.*

6. Mounting the Detector

Note: If ceiling mounted, the end with the hole (microphone end) should face the glass being protected.

1. **If using optional Wall Tamper:** Mark the mounting location for the wall tamper screw based on the final location of the detector. Then, install the wall tamper screw so that it will just make contact with the bottom of the tamper cavity when the unit is mounted. *Use a flat head M4 or M5 screw (#8 or #10).*
2. Position the unit over the wall tamper screw (if used), then mark the mounting screw and wire openings. *If required by the location, install wall anchors for the mounting screws.*
3. Secure the unit to the wall or ceiling, oriented so the microphone has the best line of sight to the protected glass. *Use M3 (#6) flat or pan head screws.*

NOTE: A screw capture feature designed to make ceiling mounting easier will cause some resistance when inserting the screw into the plastic.

7. Wiring the Detector

Refer to the wiring diagram on page 1. Pull the polling loop wires through the center Wire Entry hole and connect them to the terminal block, observing the polarity marked on the PC board. After connecting the polling loop, allow ten seconds for the unit to stabilize before testing. **NOTE:** *Accidental reverse polarity will not harm the detector or the control.*

NOTE: This sensor must be connected to a UL or ULC Listed power supply or UL or ULC Listed control unit capable of supplying a minimum of four hours of standby power.

8. Address/Serial Number ID

This detector's unique, factory-assigned serial number can be found on the bar code label on the PC board (see figure). The serial number can be entered by one of the following methods:

1. Downloading (Zone Definition screen of Compass downloading software). Recommended for large installations and installations where foot traffic cannot be controlled.
2. Manually, at the "learn" prompt during manual zone programming (see Important note below).
3. Entered by operating the detector tamper switch twice while at the "learn" prompt during manual zone programming.

IMPORTANT: If you are programming manually, be sure that other polling loop sensors are not activated so that they cannot send a signal to the control while the FG1625SN is being programmed (mask PIRs, don't open/close doors, etc.).

To enter the serial number, refer to the control's programming instructions, noting the following:

- Input Type = 6 (SL: Serial Number Polling Loop Device)
- Loop Number = 1

To fault the detector when prompted, follow the instructions under "Testing the Detector".

9. Testing the Detector

The detector should be tested at least once each year. Test the detector with the FG-701 (or GBS-7) Glassbreak Simulator. No other simulators should be used with the FG1625SN. The detector must first be placed in Test Mode (and you must close the cover.)

NOTE: In Test Mode, the LEDs are enabled and detector current can be as high as 5 mA. Be sure to exit Test Mode on completion of testing.

To enter Test Mode manually:

1. Open the front cover.
2. Use a screwdriver to short the Test Mode pads on the PC board (see diagram on next page).
3. Close the front cover.

The detector's green LED blinks approximately once per second to indicate that it has entered Test Mode.

To enter the Test Mode with the FG-701:

1. Stand within 4.6 m (15 feet) of the detector.
2. Switch the FG-701 to ACTIVATE and MANual modes.
3. Point the front of the glassbreak simulator towards the detector. Press the red START button to send a short activation code.

When the detector enters Test Mode, the green LED on the detector flashes about once per second. If the green LED does not flash, move closer to the detector and repeat the procedure. *Close the cover during test!*

Testing the Detector (flex and audio signals):

To test the FG1625SN:

1. Place the detector in Test Mode.
2. Set the tester switches to the TEST and FLEX positions.
3. Position the tester near the farthest point of the protected glass, and point it directly at the detector. If window coverings are present, close them fully and hold the tester between the coverings and the protected glass.
4. Press the red START button. The simulator clicks on and starts an 8-second armed period.
5. Generate a flex signal by carefully striking the glass with a cushioned tool. The tester responds with a burst of glassbreak audio.

If the detector receives both the flex and audio signals properly, its red Alarm LED lights for five seconds.

Testing the Detector (audio signals only):

The FG-701 can also be used to test the detector's ability to receive audio signals only. In Test Mode, when the detector receives the audio signal from the simulator, the green Event LED flickers.

Exiting Test Mode:

Test mode will automatically time out after five minutes. If you need to exit Test Mode sooner, exit by following the same procedure used to enter Test Mode.

10. LED Indicators

The detector is equipped with two LEDs: a green Event LED and a red Alarm LED. Both LEDs are normally disabled, but they are automatically enabled in Test Mode. The following table summarizes the LED messages in Test Mode.

CONDITION	GREEN LED	RED LED
Test Mode	Flash once per sec	OFF
Test Mode, event detected	Flicker	OFF
Test Mode, alarm	Flash once per sec	ON 5 seconds

11. Cover Screw

The front cover can be secured after installation. To do so, pierce the cover breakout flash and secure the front cover with a ¼-in., #4 (2.2mm) screw.

12. Nominal Glass Thickness Chart

Glass Type*	Nominal Thickness	
	Minimum	Maximum
Plate ^{3a}	2mm (3/32 in.)	10mm (3/8 in.)
Tempered	3mm (1/8 in.)	10mm (3/8 in.)
Laminated ¹	3mm (1/8 in.)	14mm (9/16 in.)
Wired	6mm (1/4 in.)	6mm (1/4 in.)
Coated ^{2,3b}	3mm (1/8 in.)	6mm (1/4 in.)
Sealed Insulating ^{1,3b, 4}	3mm (1/8 in.) [13mm (1/2 in.) overall]	6mm (1/4 in.) [19mm (3/4 in.) overall]

* Minimum size for all types is 28cm (11 in.) square; glass must be framed in the wall or mounted in a barrier at least 0.9m (36 in.) wide.

¹ Protected only if both plates in the unit are broken

² Coated glass with security films up to 0.3mm (12 mils) thick (including films for solar protection) may be used. Film Technologies International, Inc.'s GLASS-GARD GGLL 1200 has been evaluated with this product by Underwriters Laboratories, Inc. at the manufacturer's request.

³ In compliance with Underwriters Laboratories of Canada's Standard for Intrusion Detection Units (CAN/ULC-S306-M89):

- a. Plate glass 3mm (1/8 in.) to 10mm (3/8 in.) can be protected.
- b. ULC recognizes a maximum range for protecting sealed insulating glass and coated glass of 3.8 m (12.5 ft).

⁴ UL recognizes a maximum range for protecting sealed insulating glass of 6.1 m (20 ft.) with sensitivity set at maximum.

13. Specifications

Range:

7.6 m (25 ft.) maximum, omni directional

No minimum range

Operating Temperature:

-10° to 50° C (14° to 122° F)

Storage: -20° to 50° C (-4° to 122° F)

Tamper Switch:

Combination cover/ wall tamper

RFI Immunity:

10 V/m,
10 MHz - 1000 MHz

ESD Immunity:

10 kV discharges of either polarity to exposed surfaces

Power Requirements:

Input Voltage:

7 – 16 V peak-to-peak at the polling loop terminals

Current:

1 mA max, w/ LEDs disabled

5 mA max, w/ LEDs enabled

Dimensions:

115 mm x 72 mm x 27 mm
(4.5 in. H x 2.8 in. W x 1.05 in. D)

Weight:

98 g (3.5 oz.)

Packaged Product: 126 g (4.5 oz.)

Approvals / Listings:

FCC and IC verified,
UL listed, ULC listed,
CE, C-Tick

NOTICES

FCC Notice: This equipment has been tested and found to comply with the limits for a Class B digital device, pursuant to part 15 of the FCC Rules. These limits are designed to provide reasonable protection against harmful interference in a residential installation. This equipment generates, uses, and can radiate radio frequency energy and, if not installed and used in accordance with the instructions, may cause harmful interference to radio communications. However, there is no guarantee that interference will not occur in a particular installation. If this equipment does cause harmful interference to radio or television reception, which can be determined by turning the equipment off and on, the user is encouraged to try to correct the interference by one or more of the following measures: 1) Reorient or relocate the receiving antenna, 2) Increase the separation between the equipment and receiver, 3) Connect the equipment into an outlet on a circuit different from that to which the receiver is connected. The installer can also consult an experienced radio/television technician for additional suggestions, if necessary.

IC Notice: This Class B digital apparatus meets all requirements of the Canadian Interference-Causing Equipment Regulations.

Cet appareil numérique de la Classe B respecte toutes les exigences du Règlement sur le matériel brouilleur du Canada

